

UNI-EN 12845 fire-fighting systems

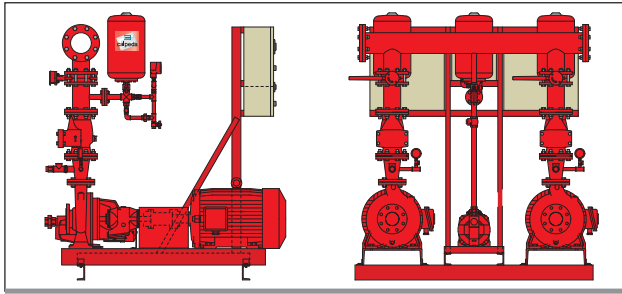

AUE, AUD, AUED

UNI-EN 12845 fire-fighting systems



AUE 11

UNI-EN 12845 units with 1 N series electric main pump

AUE 21

UNI-EN 12845 units with 2 N series electric main pumps

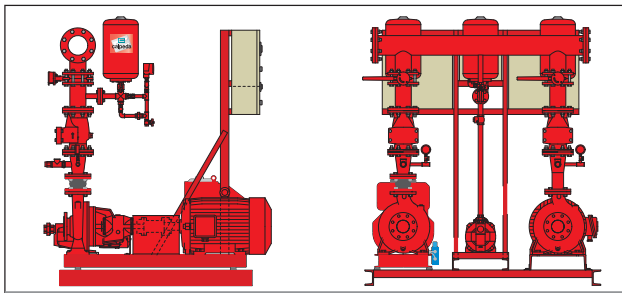

AUD 11

UNI-EN 12845 units with 1 N series main pump (diesel motor)

AUED 21

UNI-EN 12845 units with 2 N series main pumps (electric and diesel motors)

Construction

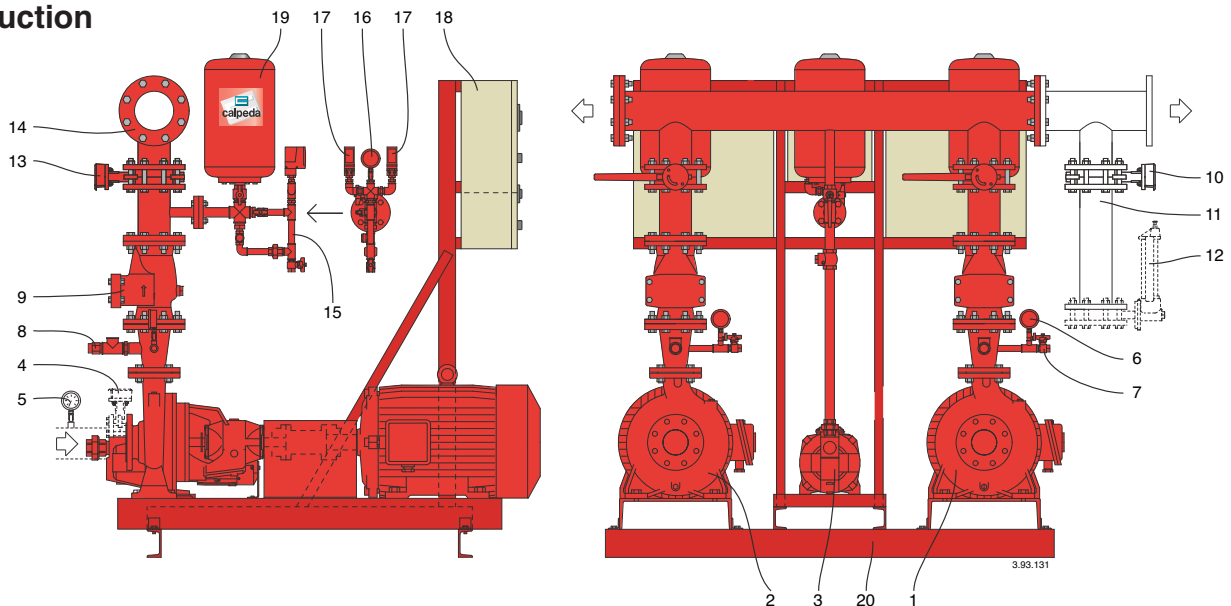

- 1) Main pump
- 2) Main pump
- 3) Jockey pump
- 4) Butterfly valve in suction section (on request only for installation with positive head)
- 5) Vacuometer
- 6) Pressure gauge in delivery section
- 7) Ball valve for draining
- 8) Adjusted diaphragm
- 9) Non-return valve (accessible)
- 10) Butterfly valve for capacity-check system (on request)
- 11) Manifold for flow meter (on request)
- 12) Flow meter (on request)
- 13) Butterfly valve or ball valve in delivery section
- 14) Delivery manifold
- 15) Test circuit (manual) (one for each pump)
- 16) Pressure gauge
- 17) Starting pressure switches of main pumps
Starting pressure switch to stop jockey pump
- 18) Electric boxes (one for each pump)
- 19) Diaphragm tanks
- 20) Steel base for all pumps

All the butterfly valves or ball valve are locked in the normal position by means of a lock and key.
On request: anti-vibration couplings in both the suction and delivery sections.

AUE, AUD, AUED

UNI-EN 12845 fire-fighting systems



Construction

Units constructed in accordance with UNI-EN 12845 standards for automatic fire-fighting systems (with sprinkler) and according to UNI 10779 for fire-fighting systems with fire hydrants.

The units may be composed of 1 or 2 main pumps.

Units are fitted with a jockey pump, with which the system pressure level can be maintained without having to start the main pumps.

Application

For feeding water to automatic fire-fighting systems and units with hydrants.

Operation

The pumps start operating after a fall in the pressure level in the fire-extinguishing system.

The first pump to be triggered is the jockey pump.

If this pump cannot restore the pressure level, the main pump starts. When there is more than one main pump, the pumps start in cascade sequence, with the starting pressure switches set at different pressure levels.

The pressure switches of the main pumps are used only for starting, as the pumps must be stopped manually for UNI-EN 12845 units or automatically with a timer for UNI 10779 sets.

The recirculation diaphragm allows for operation of the main pumps also when the delivery port is closed (with no consumption of water in the system), avoiding overheating of the water inside the pump body.

Weekly test

The programmable clock in the electric box controls the forced starting of the main pump (electric driven pump only).

The diaphragm avoids overheating of the water in the pump body.

Pumps

Main pumps

The main pumps can be :

N series: single stage horizontal centrifugal pumps

The N series centrifugal pumps are coupled with the electric or diesel motor through a bearing coupling. This solution allows to operate on the hydraulic part without moving the motor.

Jockey pump

Jockey pump can be a self-priming jet pump, a centrifugal pump with two impellers, a vertical multistage pump or a submersible borehole pump.

The maximum pressure developed by the jockey pump is always greater than the pressure of the main pumps.

Motors

Two-pole induction type, 50 Hz, n = 2,900 rpm

Three-phase 230/400V ± 10% up to 3 kW

400/690V ± 10% 4 kW and higher.

Insulation class F

Protection IP 54 for close coupled pumps, IP 55 for pumps with coupling.

Construction in accordance with: IEC 60034

Other voltage and frequency ratings available on request

Diesel motors (for standardised N-series pumps)

These are direct-injection pumps fitted with electric control box, fuel tank, starter batteries and silencer.

Hydraulic components

Each main pump is fitted with:

- Pressure and vacuum gauge in the suction section.
- Butterfly valve in the suction section (on request only for installation with positive suction head).
- Pressure gauge in the delivery section.
- Adjusted diaphragm.
- Pressure switch to indicate the pump is operating.
- Non-return valve of the accessible swing-type.
- Butterfly valve in the delivery section.
- Manual test circuit with pressure switches, pressure gauge, non-return valve and ball valve and cylindrical 20-liter (15 bar) tank (one for each pump).

The jockey pump is fitted with:

- Ball valve in the suction section (on request only if the pump has a positive suction head).
- Non-return valve and ball valve in the delivery section.
- Manual test circuit with pressure switch, pressure gauge, non-return valve and ball valve and cylindrical 20-liter (15 bar) tank (one for each pump).

Other components:

- Delivery manifold.
- Coupling for connection of a priming tank (only for the pumps installed with positive suction head).
- The suction manifold is never supplied as such execution is forbidden by the standards.

On request:

- Manifold for flow meter.
- Adjusted-flange, diaphragm type, flow meter.

Electric boxes

Electric main-pump box (electric motor)

Each main pump has its own electric control board housed in a metal cabinet with IP54 protection. The box contains the devices required for operation and control of the pump.

Motor starting is direct for power ratings up to 7.5 kW.

For motors with a rating equal to or higher than 11 kW pump starting is of the Y/Δ type with fuses, contactors and timer.

- programmable clock for the weekly test.
- Timer for pumps stop after 20 minutes (UNI 10779)

The following devices are located on the internal door panel:

- Line-sectioning handle - Voltmeter and ammeter with switch
- "Manual-0-Automatic" selector with extractible key only in "automatic" position - Start/Stop pushbuttons - Pilot lights to indicate: no-volt, pump running, voltage on.

Electric main-pump box (diesel motor)

This cabinet contains the electronic control devices for the control of the diesel motor and the battery chargers for feeding the starter accumulators.

The following devices are located on the front of the box:

- Line-sectioning handle.
- Front panel of the electronic unit.
- Manual-0-Automatic selector with extractible key only an "automatic" position.

Electric jockey-pump box

When installed, the jockey pump is fitted with its own electric panel, metal housing with IP 54 protection.

Control box (on request).

To be installed in a place to be looked after, to signal any possible failure of the unit state. It must be connected to V.220 and it gives an acoustic and visual signal for 24 hours.

Designation of units

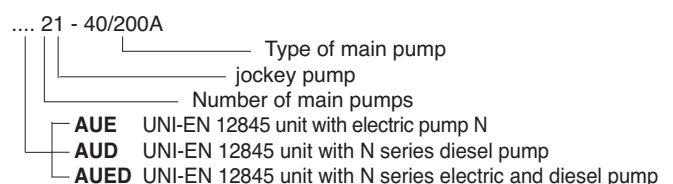

With 1 electric pump

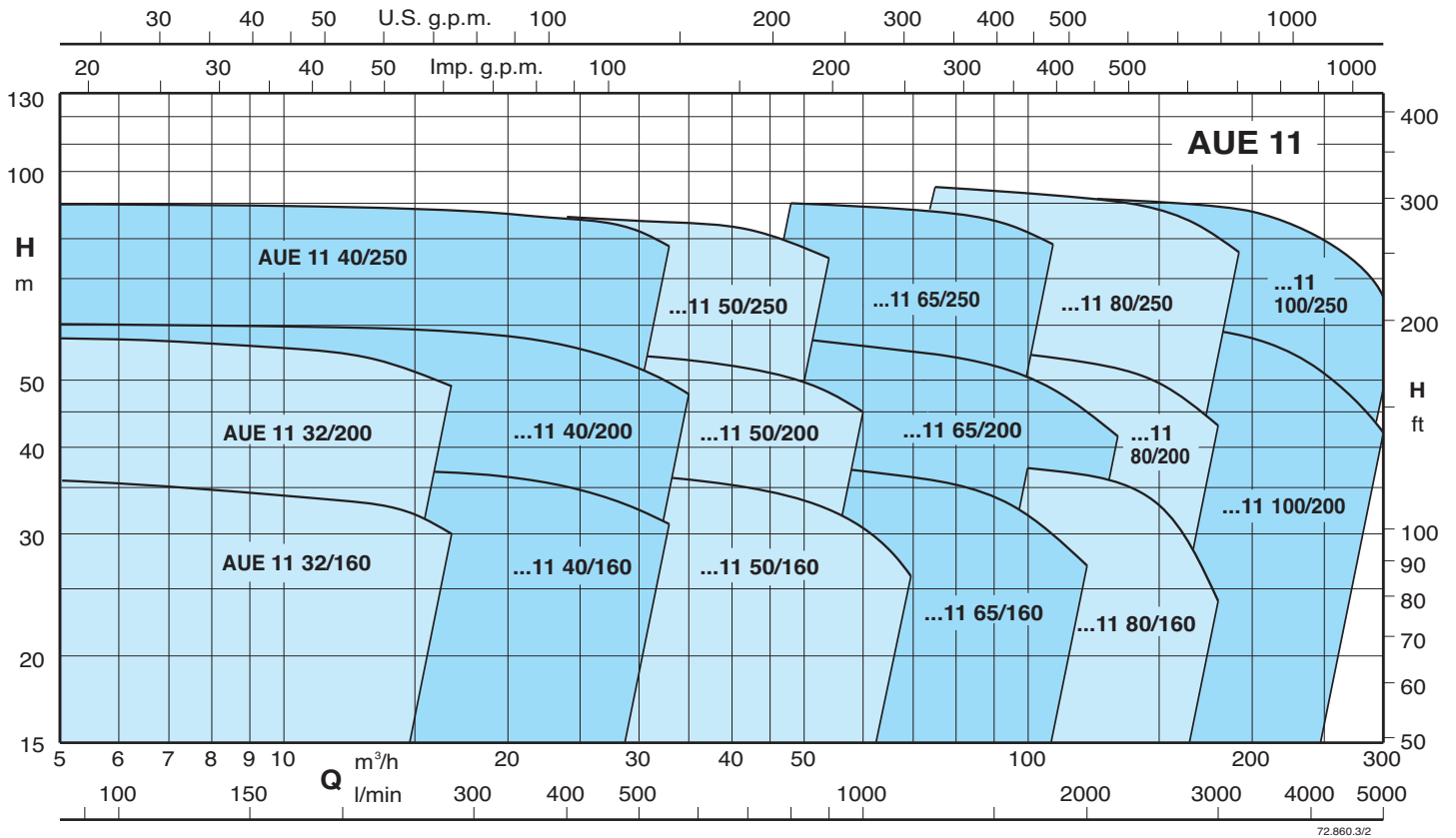

With 2 electric pumps

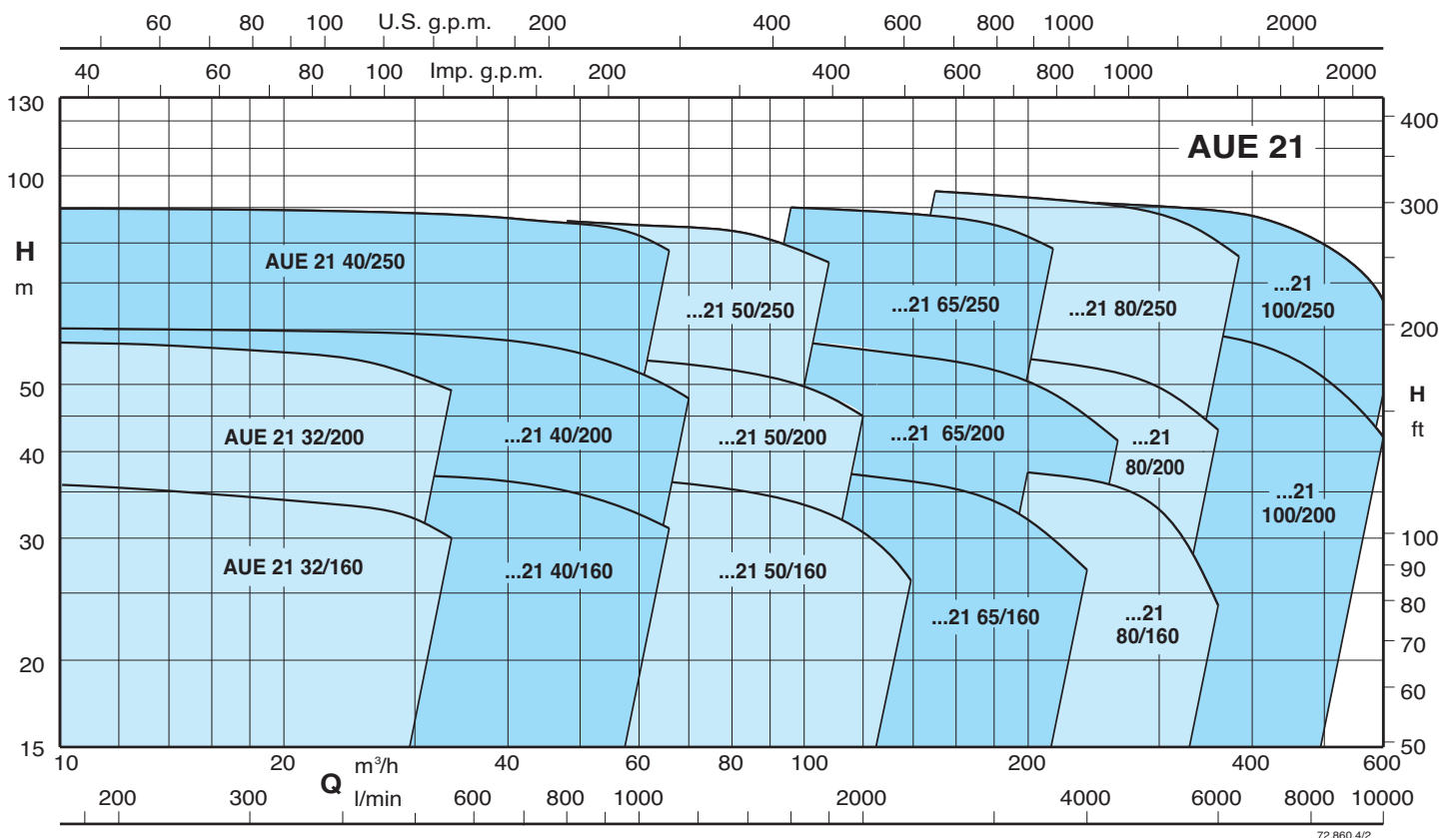

AUD - AUED

UNI-EN 12845 fire-fighting systems



With 1 pump (diesel motor)

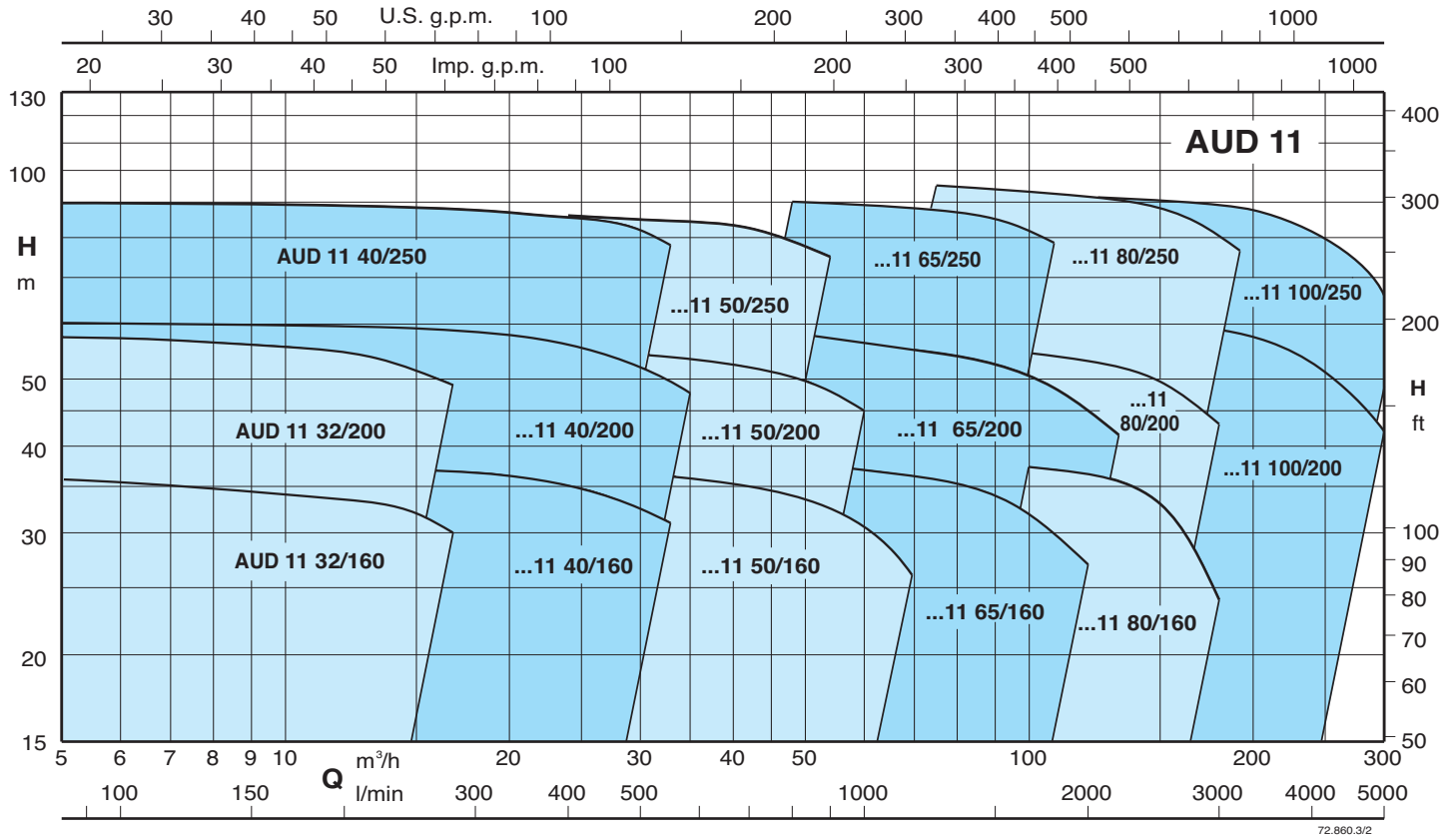

With 2 pumps (electric and diesel motors)

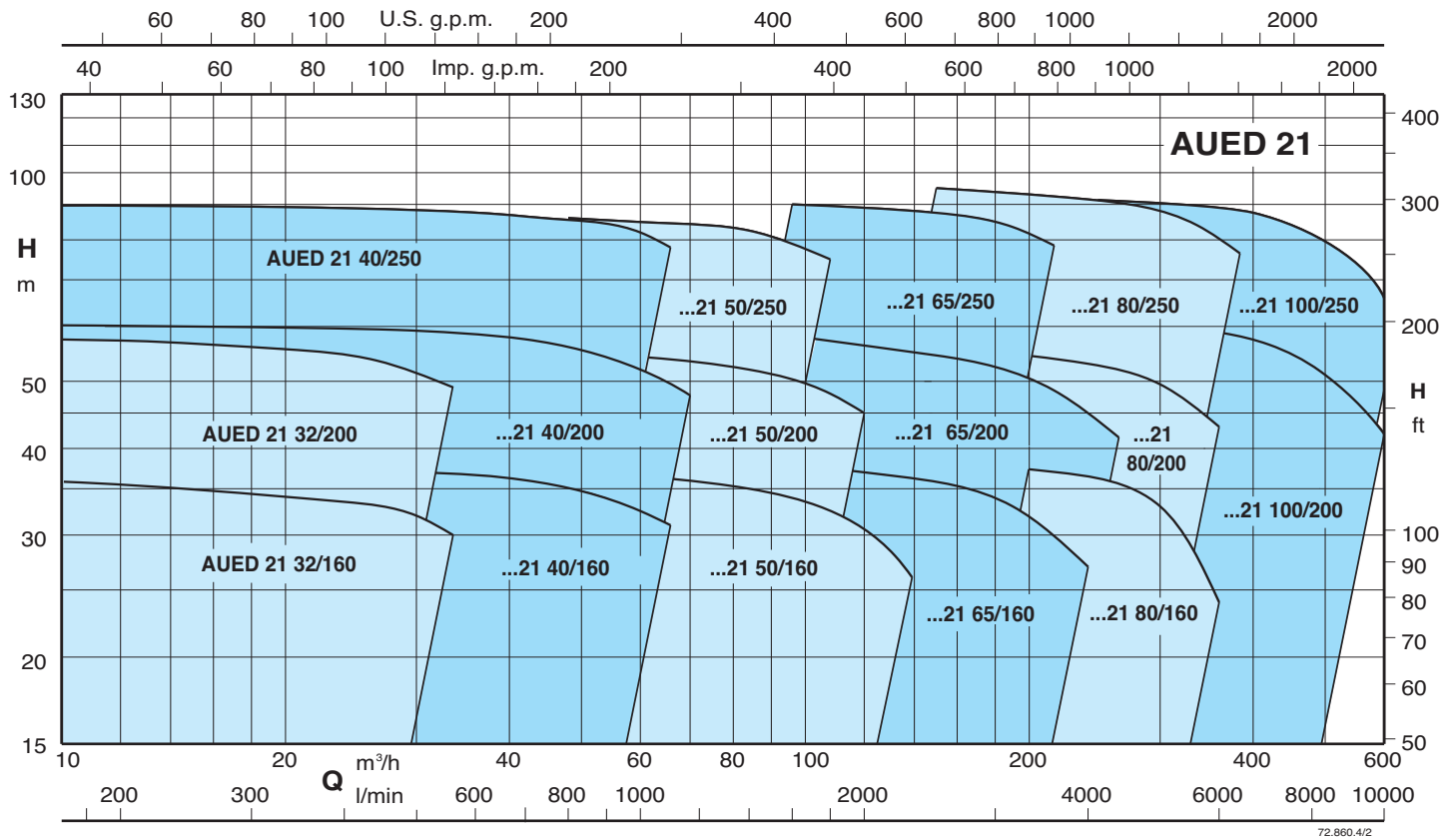

Characteristics of full-jet nozzles

Capacity

Pressure bar	Nozzle diameter mm			
	10	12	16	20
	Flow-rate l/min			
3	115	165	295	460
4	130	190	340	530
5	150	215	380	590
6	160	235	415	650
7	175	250	450	700
8	185	270	480	750

Water-jet range

Pressure bar	Nozzle diameter mm			
	10	12	16	20
	Range m			
3	10 a 20	11 a 22	15 a 30	16 a 33
5	11 a 23	11 a 25	17 a 33	18 a 36
8	12 a 26	12 a 30	19 a 36	20 a 40

Characteristics of sprinkler nozzles

Capacity

Pressure bar	Rated diameter of orifice mm		
	10	15	20
	Flow-rate l/min		
2	80	113	162
3	98	139	199
4	114	160	230
5	127	180	258
6	139	196	282
7	150	214	305
8	161	226	325
9	171	240	345